

# Electric Motors Are The Single Largest User Of Energy

in Industrial/Commercial facilities and can account for up to 70% of their total energy consumption. Electric motors are found in everything from pumps and compressors, to heating and cooling systems, to hoists and material handling equipment.

Bearings are a major component of electric motors and are responsible for axially locating the rotor, keeping the air gap between the rotor and stator small and consistent, as well as supporting and transferring the rotor and shaft loads to the motor frame. Along with these requirements, electric motors demand bearings that will allow variable speed operation with minimum friction, noise, and power consumption.

According to the Institute of Electrical and Electronics Engineers (IEEE) over half of all electric motor failures are bearing related. Consequently, the electric motor designer/ rebuilder needs to carefully consider the application requirements when selecting bearing types and mounting arrangements.

Koyo has been providing reliable quality products to the North American electric motor replacement market and Original Equipment Manufacturers since 1958. Over those 55+ years Koyo Engineers have gained valuable experience providing solutions to the toughest electric motor applications including:

## Mill Duty Motors

Increased downtime and high energy costs are often associated with electric motors found in mill duty applications. Typically motors in these environments face high levels of contamination, heavy loads, and high duty cycles.

## Variable Frequency Drives (VFD's)

With the large demand for increased energy efficiency the use of VFD's has also increased. As a result of more frequent VFD usage there has been a rise in motor bearing failure due to the increased introduction of stray or "dirty" electrical current that causes electrical discharge damage or "fluting" in the motor bearings. To combat this, Hybrid-Ceramic Bearings are recommended based on their insulating properties.

## Wind Turbine Generators

Generators convert the mechanical energy obtained from the wind into electrical energy. Radial ball bearings are the most commonly used bearing due to the low friction and capacity requirements of this application.



## Hybrid-Ceramic "3NC" Ball Bearings

Eliminate electric arcing

Bearing Applications

- variable frequency drives
- high speed motors
- conductive environments
- pumps
- DC controller motors
- inverter duty motors

Ceramic vs. Steel Balls

Hybrid-Ceramic Balls

- lighter
- less slip of rolling elements
- low temperature increase
- improved rigidity
- longer grease service life
- allows 30 - 50% improvement in speed
- double shielded and filled with Exxon Polyrex<sup>®</sup> EM Grease

Features & Benefits

Ceramic Balls Replace Steel Balls to Insulate the Bearings & Interrupt the Flow of Current

- non-magnetic & non-conductive
- elimination of electric arcing or fluting for extended bearing life
- dimensionally interchangeable with current bearings
- increased speeds (up to 50% higher than steel ball bearings) resulting from ceramic balls being 60% lighter than steel balls
- improved cost efficiency through reduced downtime, maintenance and replacement
- Eliminates the need for insulated sleeves



## Angular Contact Ball Bearings

Increased thrust load capabilities

Bearing Applications

- vertical applications
- thrust applications
- high speed spindles
- industrial pumps

Features & Benefits

- ball guided cage design
- machined bronze retainer to offer more strength than pressed brass or steel for higher operating speeds
- universally ground to give equal load sharing or Duplex mounting back-to-back (DB); face-to-face (DF); and tandem (DT)
- duplex DB - intended for rigid radial support only with the outer rings floated in the housing
- duplex DF - intended for combined loads with thrust from either direction
- duplex DT - intended for very heavy thrust loads in one direction
  - superfinished raceways - for reduced vibration and quieter operation
  - ABEC 5 & 7 available for up to 50% higher speeds
- available with ceramic balls for 30 - 50% higher speeds

## "N" Series (29000) Spherical Thrust Bearings

Superfinished rollers and raceways achieve higher speeds with a reduction in noise

Bearing Applications

- deep well pump motors
- high thrust applications

Features & Benefits

- superfinished for:
  - reduced noise • less vibration
  - higher speeds • quieter operation
- bronze retainer for:
  - reduced vibration • quieter operation
  - higher operating speeds
  - longer service life under poor lubricating conditions



## Standard Single Shielded Bearings

Eliminate grease compatibility issue

Bearing Applications

- all electric motors

Features & Benefits

- standard radial ball bearing with single shielded, double shielded or unshielded
- with single shielded and unshielded bearings, users can lubricate the bearing with proper grease for the operating environment and prevent grease incompatibility



## "RD" Type (Extremely Light Contact) Sealed Ball Bearings

Superior performance through a dynamic seal design and low operating torque

Bearing Applications

Most electric motors, including, but not limited to:

- reduction motors
- fan motors
- propeller shaft centers
- electromagnetic clutches
- high efficiency motors
- washdown motors

Features & Benefits

- mandrel reinforced synthetic rubber seal
- outer lip flexibility for reduced friction torque, lower operating temperature and longer bearing life
- inner lip seal prevents grease leakage and directs grease towards the bearing for better lubrication
- labyrinth design offers optimum seal to resist penetration of contaminating elements
- lower starting and running torques reduce operating costs compared to all RS type bearings



## Cylindrical Roller Bearings

Designed for optimum performance

Bearing Applications

- compressor motors
- crusher duty motors
- motors with excessive overhung loads

Features & Benefits

- machined bronze retainer for reduced vibration, quieter operation and higher operating speeds
- high radial load capacity to accommodate heavy radial loads and impact loading
- separable inner ring or outer ring to simplify mounting and dismounting
- "NU" Type (Free Side Bearings) available to adjust for shaft's axial movements relative to the housing position
- "NJ" Type available to carry axial load in one direction
- increased load carrying capacity



Koyo is the JTEKT Corporation brand for Bearings. JTEKT engineering and manufacturing capabilities range from super large bearings with outer diameters of seven meters to miniature bearings with inner diameters as small as one millimeter. Utilizing new materials and the latest in manufacturing technology, JTEKT Corporation has developed hybrid ceramic bearings and a variety of extreme special environment bearings to meet the increasingly severe and demanding requirements of modern industries. JTEKT Corporation stands at the forefront, as a technological leader in the world bearing industry.

JTEKT Corporation owns and operates over 25 bearings plants in seven countries and 6 R&D Technical Engineering Centers on three continents. Koyo offers innovative solutions to both original equipment manufacturers and aftermarket end users focusing on key markets such as automotive, agriculture and construction, heavy industry (steel & wind mill), gear, reducer, electric motor and general machinery.

## Glossary of Terms

**ARCING** - a phenomenon where the surface melts locally because sparks are generated as the electricity passes through the ultra-thin oil layer and into the bearing while rotating.

**BRINNELING** - a small surface indentation generated either on the raceway through plastic deformation or on the rolling surfaces due to heavy loading on a stationary or slow speed bearing.

**BORE** - Inside diameter of inner ring.

**INTERNAL CLEARANCE** - can be either radial or axial and is the total distance that either the inner or outer ring can be moved relative to the other.

**L10 LIFE** - The total number of revolutions or hours until 90% of bearings being operated under the same conditions are left without flaking damage. Also known as fatigue life of bearing.

**PRELOAD** - Axial load applied to a tapered and angular contact ball bearings resulting in a axial deflection or negative axial clearance of the bearings or a radial preload from press fits.

**STATIC LOAD RATING** - the static load or impact load level which when applied to a stationary bearing will produce a permanent deformation or brinell mark.

**SNAP RING** - a fastener that holds components or assemblies onto a shaft or in a housing/bore when installed in a groove.

## Seals / Shields / Snap-Ring Codes & Interchanges

One Side	Both Sides	Description	Interchanges								
			FAG	MRC	Nachi	NSK	NTN	SNR	SKF	Fafnir	
Z	ZZ	Fixed Shield (s)	Z/ZZ	F/FF	Z/ZZ	Z/ZZ	Z/ZZ	Z/ZZ	Z/ZZ	Z/ZZ	D/DD
ZX	ZZX	Removable Shield (s)	N/A	L/LL	ZS/ZZS	ZS/ZZS	ZA/ZZA	N/A	N/A	N/A	N/A
RU	2RU	Non-Contact Seal (s)	RSD/2RSD	N/A	NKE/2NKE	V/VV	LB/LLB	N/A	RZ/2RZ	PL/PPL	
RS	2RS	Contact Seal (s)	RS/2RS	Z/ZZ	NSL/2NSL	DU/DDU	LU/LLU	E/EE	RS/2RS	P/PP	
RK	2RK	Dip Lip Contact Seal (s)	N/A	N/A	N/A	N/A	LC/LLC	E10/EE10	N/A	Y/YY	
RD	2RD	Extremely Light Contact Seal (s)	HRS/2HRS	N/A	NSE/2NSE	N/A	LH/LLH	N/A	RSL/2RSL	V/VV	
RDT	2RDT	Same as 2RD - for Large Size Ball Bearings	N/A	N/A	NSE/2NSE	N/A	LH/LLH	N/A	N/A	V/VV	
NR		Snap Ring on Outer Ring OD	NR	G	NR	NR	NR	NR	NR	G	



## Electric Motor Repair Solutions

# REPAIR



# Who Do Your Customers Trust to fix their electric motor failures?

### Did You Know:

According to the Institute of Electrical and Electronics Engineers (IEEE) over half of all electric motor failures are bearing related.

Koyo's Certified Repair Program is geared towards improving a shop's overall bearing knowledge and eliminating typical failure modes associated with bearings and electric motor repairs.

The program encompasses a 4-step process starting with a comprehensive shop audit by a Koyo representative, leading to a custom designed training class, followed by a certification exam for shop personnel, and lastly, a 3-year check up to make sure certification requirements are still intact.



To become a Koyo Certified Repair Center or to locate one near you, please visit our website

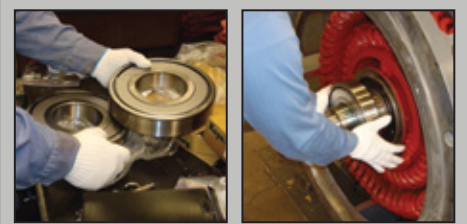

## www.JTEKT.NA.com

For more information on this program including costs to participate please contact your local authorized Koyo Bearing Distributor



### The Program:

#### Benefits

- Strengthen customer loyalty
- Increased consistency of repairs
- Recognition of facility's capabilities
- Improved technician performance
- Demonstrates continuous improvement
- Reduction in warranty returns

#### Custom Training

Based on the results of the initial shop audit inspection one of our bearing experts will develop a custom training around these topics:

- Bearing Basics
- Proper Storage and Handling
- Mounting Procedures
- Lubrication Principles
- Bearing Failure Troubleshooting

# Koyo®

BALL, NEEDLE & ROLLER BEARINGS

JTEKT North America Corporation  
www.JTEKT-NA.com

### RD Energy Efficient Light Contact Sealed Ball Bearings

Koyo's unique seal design reduces seal drag and energy consumption in electric motor applications while providing superior seal performance and grease retention.

Koyo's RD Type Light Contact Sealed Ball Bearings provide a two-fold benefit to standard sealed bearings:

- Innate design characteristics of the RD Seal **REDUCES DRAG, FRICTIONAL TORQUE, and OPERATING TEMPERATURE.**
- The closure provided from the RD Seal is superior to standard seals, helping to inhibit the ingress of contaminants and moisture.

Optimal design selection and mechanical advantages from the RD translate into longer life and increased efficiency in electric motor applications.

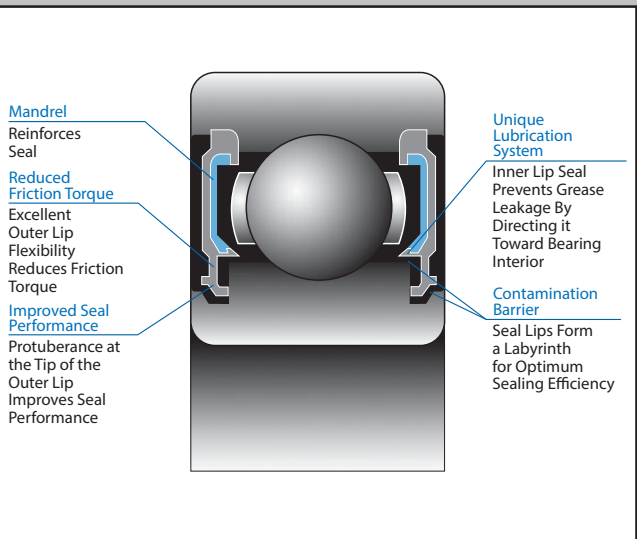

### 3NC Ceramic Hybrid Bearings

Bearings used in electrical motor applications are subject to electric pitting – a phenomenon where the surface melts locally because sparks are generated as the electricity passes through the ultra-thin oil layer and into the bearing while rotating. This is one of the main factors that can lead to damage and reduce bearing service life. To combat this Hybrid-Ceramic Bearings are recommended based on their insulating properties.

Compared to steel balls, ceramic balls are lighter, smoother, harder, and resistant to both corrosion and electrical currents. These characteristics allow for the following performance enhancements:

- **LOWERS OPERATING TEMPERATURES** (up to as much as 40%) resulting in longer grease life
- **LOWER ROTATIONAL TORQUE** than steel bearings which means less energy is required to rotate the bearing
- **ELIMINATES ELECTRIC ARCING OR FLUTING** by insulating the bearing from stray currents

Note: All of Koyo's Hybrid-Ceramic Ball Bearings are form, fit, and function to their standard steel size counterpart.

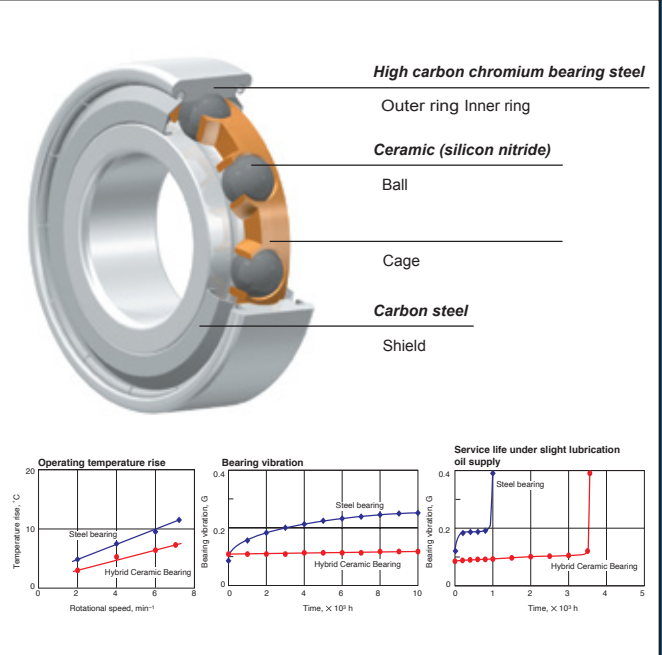

### Ball Guided Angular Contact Ball Bearings

Designed for high accuracy and excellent high-speed performance. Angular contact ball bearings are designed to carry combined loads; both axial and radial. To help with vertical pump applications Koyo adopted a ball guided design (B-5GC3 FY) which provides the following benefits:

- **OPTIMIZED FOR BETTER LUBRICATION FLOW**
- **40° CONTACT ANGLE** for better axial load carrying capabilities
- **BRONZE CAGE** for use in marginal lubrication applications
- Symmetrical design **REDUCES VIBRATION** & bearing imbalances
- **LOWER ROTATING MASS** resulting in better energy efficiency
- **FLUSH GROUND** for multiple mounting arrangements

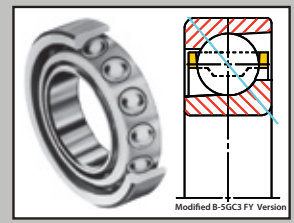

### Koyo Offers A Line Of Bearing Maintenance Tools



Proper Handling And Installation Procedures Have A Major Impact On A Bearing's Life